

Thank you for purchasing this TradeQuip product. Manufactured to a high standard this product will, if used according to these instructions and properly maintained, give you years of trouble free performance.



**IMPORTANT: PLEASE READ THESE INSTRUCTIONS CAREFULLY. NOTE THE SAFE OPERATIONAL REQUIREMENTS, WARNINGS & CAUTIONS. USE THE PRODUCT CORRECTLY AND WITH CARE FOR THE PURPOSE FOR WHICH IT IS INTENDED. FAILURE TO DO SO MAY CAUSE DAMAGE AND/OR PERSONAL INJURY, AND WILL INVALIDATE THE WARRANTY. PLEASE KEEP INSTRUCTIONS SAFE FOR FUTURE USE.**

## 1. SAFETY INSTRUCTIONS

- Only use this Mobile Workshop Table for the purpose for which it has been designed.
- This Mobile Workshop Table is designed to roll easily on flat surfaces and should not be used on uneven or inclined surfaces. Do not pull the Workshop Table, Table can tip or fall causing damage or injury.
- Do not modify any component of this Mobile Workshop Table.
- When servicing, use only TradeQuip identical replacement parts. Use of any other parts will void the warranty.
- Safe Working Capacity 45kg



## 2. ASSEMBLY INSTRUCTIONS

### Assembly Instructions

1. Cover #1 ABS tool tray on the #6 steel top tray.
2. Use #7 bolt to connect the #5 tool holder, #1 ABS tray and fasten.

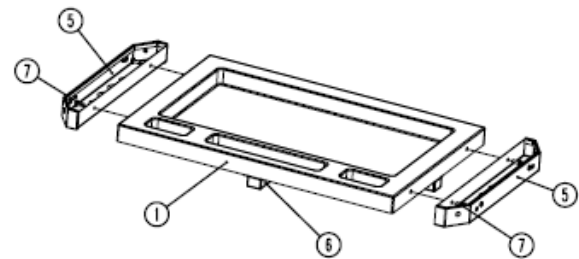

FIG: A

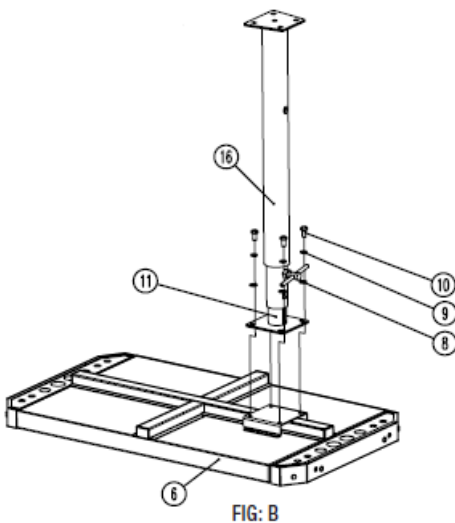

FIG: B

3. Connect #6 steel top tray and #11 inner support tube, then use #8 flat washer, #9 spring washer, #10 bolt to fasten all the spare parts.

4. Use #17 fasten nut, #18 flat washer to assemble the #19 swivel castor and #21 locking castor with #20 bottom frame.
5. Ensure the #21 locking castors are assembled on the rear legs as per FIG C.
6. Use #22 bolt, #8 flat washer, #9 spring washer, #10 bolt to assemble the #16 outer support tube, with #20 bottom frame.

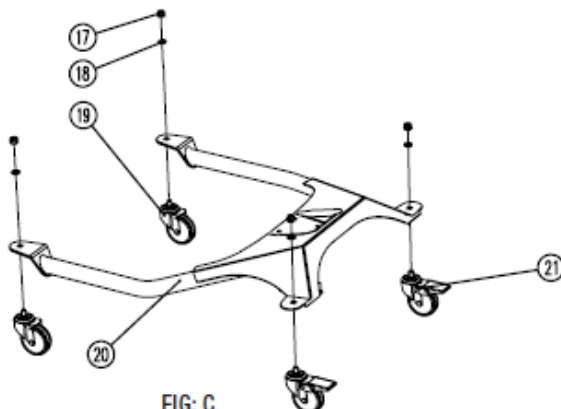

FIG: C

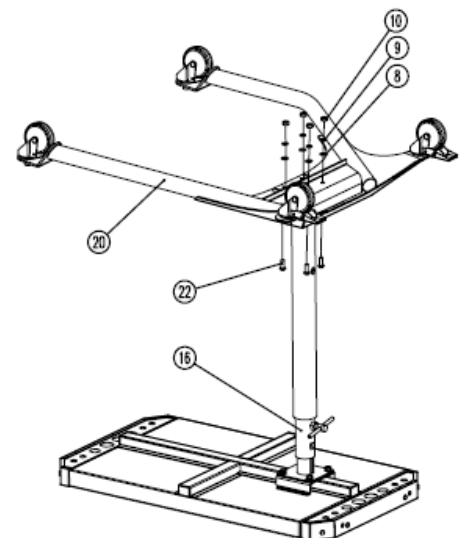

FIG: D

7. Ensure all fasteners are secure.

### 3. SPECIFICATIONS

- Safe Working Capacity: 45kg
- Adjustable Working Height: 900-1230mm
- Castor Wheel Diameter: 75mm
- Table Top Dimensions: 809L x 475W x 42Hmm
- Main Tray Dimensions: 580L x 308W x 38Hmm
- Overall Dimensions: 870L x 755W x 942Hmm
- Nett Weight: 19.5kg

### 4. PARTS LIST & PARTS DIAGRAM

Part #	Description	QTY
1	ABS Plastic Tool Tray	1
2	Plastic Tube Cap	4
3	Plastic Insert	8
4	Bumper	2
5	Tool Holder	2
6	Steel Top Tray	1
7	Bolt M8 x 16mm	4
8	Flat Washer M8	8
9	Spring Washer M8	8
10	Bolt M6 x 16mm	4
11	Inner Support Tube	1
12	Adjust Knob	1
13	Rubber Cap	1
14	Bolt M5 x 8mm	1
15	Protector Foam	1
16	Outer Support Tube	1
17	Fasten Nut M10	4
18	Flat Washer M12	4
19	3" PVC Swivel Castor	2
20	Bottom Frame	1
21	3" PVC Castor w/locking	2
22	Bolt M8 x 25mm	4
23	Nut M8	4

